



## ORION 918CX RAPISCAN

COMPACT BAGGAGE AND PARCEL INSPECTION SYSTEM

- INDUSTRY BEST RESOLUTION & MATERIAL DISCRIMINATION
- EXPLOSIVES & NARCOTICS DETECTION
- LOW DENSITY IMAGE ENHANCEMENT
- MATRIXING, NETWORKING & REMOTE VIEWING

### SPECTRUM 4-COLOR IMAGING

918CX can present images to the operator in the Classic 4-color and the new proprietary Spectrum 4-color (SP4) option providing superior image, allowing improved security by quick and accurate identification of threats and increase in throughput.

### DUAL MODE $Z_{EFF}$

This feature aids the operator in quick identification of organic materials, either in Range Mode which highlights areas based on operator selected Z-effective values of 7, 8 or 9, or in Interactive Mode which gives the operator the option to display the Z-effective number of a selected pixel.

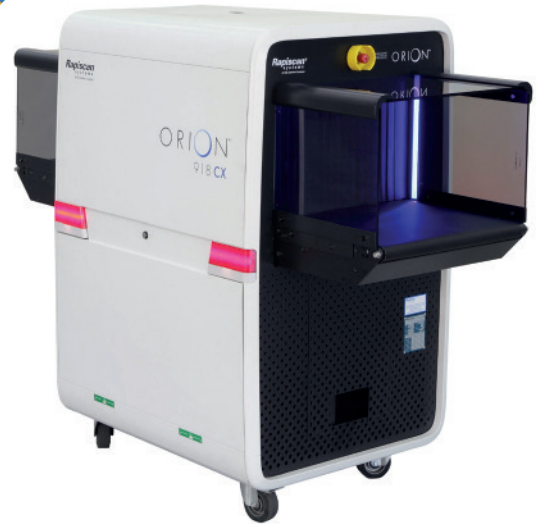

TUNNEL OPENING (W X H):  
540MM X 360MM

THE NEW 918CX IS A HIGH PERFORMANCE, COMPACT AND VERSATILE 540MM BY 360MM TUNNEL X-RAY SYSTEM WITH EXCEPTIONAL IMAGE QUALITY AND EXCELLENT THREAT DETECTION ALERT CAPABILITIES.

### EXPLOSIVES AND NARCOTICS DETECTION

Target and NARCSan are designed to detect a wide range of explosives and narcotics respectively in real time during the scanning process by marking a potential threat on the X-ray image. Rapiscan® Systems detection algorithms are based on regulatory approved material analysis techniques.

### EUROPEAN AVIATION COMPLIANCE

918CX performance is in full compliance with the mandatory regulations (EC) No. 300/2008, (EC) implementing regulation 1998/2015 and update 815/2017, EC implementing decision 8005/2015 and update 3030/2017 for aviation security in the European Union.



# ORION 918CX RAPISCAN

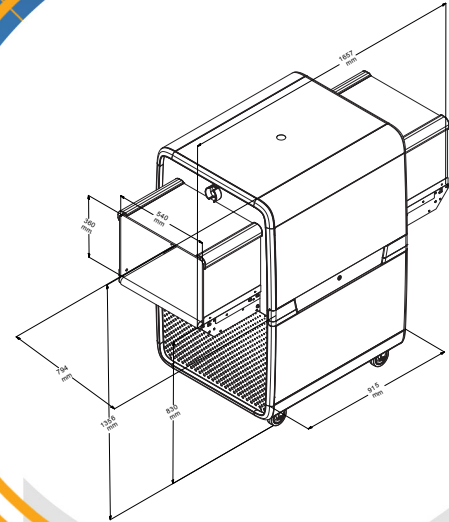

## PHYSICAL SPECIFICATIONS <sup>1</sup>

Dimensions	L : 1,657 mm
	W : 794 mm
	H : 1,356 mm
Tunnel Size	W : 540 mm
	H : 360 mm
Conveyor Height	830 mm
Weight (net)	414 Kg

## ENVIRONMENT & POWER

Storage temperature	-20°C to 50°C
Operating temperature	0°C to 40°C
Relative humidity	5 to 95% non-condensing
System power	100/110/120/200/208 /220/230/240 VAC 310%

## PERFORMANCE <sup>2</sup>

Conveyor speed <sup>1</sup>	0.20 m/sec (39.4 ft/min)
Conveyor load <sup>1</sup>	165 Kg
Steel penetration	33 AWG typical 31 AWG standard
Wire resolution	40 AWG typical 38 AWG standard
Spatial resolution	0.8 mm vertical & horizontal

## HIGH SPEED OPTION

Conveyor speed <sup>1</sup>	0.35 m/sec (68.9 ft/min)
Steel penetration	30 mm typical 29 mm standard
Wire resolution	36 AWG typical 34 AWG standard
Spatial resolution	0.8 mm vertical & horizontal

## X-RAY GENERATOR

Anode voltage	140kV
Orientation	Diagonally upward

## KEY FEATURES AND OPTIONS

- Explosive threats, narcotics & density alerts
- Spectrum 4
- 17 Image processing functions
- SINERGY low density enhancement
- Dual Mode Z-effective
- CrystalClear™
- Automatic, Enhanced Image Archiving
- E.U. Approved Threat Image Projection
- Remote Status Monitoring
- Remote Archive Review
- Multi-System Alarm resolution Network
- 13 Languages
- 64-bit Operating System

1. Approximate Values

2. Stated performance as measured by Rapiscan® Imaging Validation Test Kit

## HTDS

Parc d'Activités du Moulin de Massy - 3 rue du Saule Trapu  
BP246 - 91882 Massy Cedex France

Tel : +33 (0) 1 64 86 28 28 - Fax : +33 (0) 1 69 07 69 54 - info@htds.fr - www.htds.fr

HTDS Algeria : +213 232 384 01/02

HTDS Morocco : +212 222 749 59

HTDS Egypt : +202 229 053 06

HTDS Lybia : +218 91 69 50 70 8

HTDS Madagascar : +261 34 40 664 72

HTDS Tunisia : +216 70 836 961