



627DV RAPISCAN

LARGE TUNNEL WITH DUAL VIEW TECHNOLOGY FOR COMPREHENSIVE X-RAY SCREENING OF LARGE BAGGAGE AND PARCELS

- ▶ LARGE BAGGAGE AND PARCEL SCREENING
- ▶ MEETS GLOBAL REGULATORY REQUIREMENTS
- ▶ NETWORK ENABLED
- ▶ COST EFFECTIVE

STANDARD FEATURES

- Multi energy imaging (4 Color)
- View previous/next bag
- Image archive
- Configurable image processing keys
- Baggage counter
- Date / time display
- Search indicator
- UPS (Uninterrupted Power Supply)
- Multi language support
- Flat panel monitor

STANDARD IMAGE PROCESSING FUNCTIONS

- Crystal clear™
- Black and white
- Organic / inorganic stripping
- Inverse video
- High penetration
- Pseudo color
- Low penetration
- Variable edge enhancement
- Variable color stripping
- Variable gamma
- Variable density
- Dynamic continuous zoom & panning
- Fixed zoom (64x)

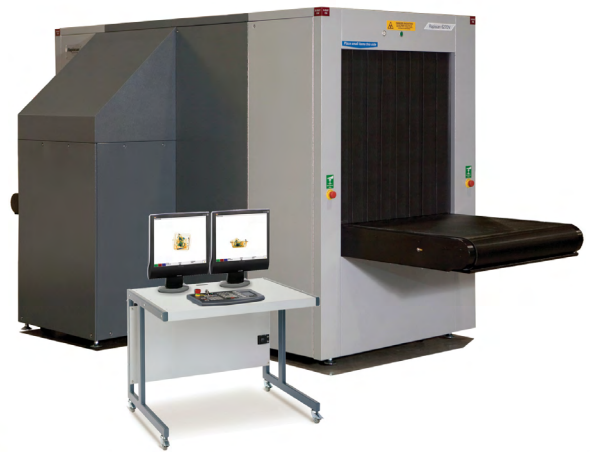

TUNEL OPENING (WXH) :
1,000 x 1,000 mm (39.4 x 39.4 in)

WITH A LARGE TUNNEL OPENING OF 1,000 MM X 1,000 MM, THE **RAPISCAN 627DV** IS DESIGNED FOR SCREENING SMALL CARGO AND PARCELS FOR CUSTOMS, AIR CARGO AND INFRASTRUCTURE PROTECTION SCREENING APPLICATIONS.

The Rapiscan 627DV has been approved and included on the U.S. TSA Air Cargo Screening Technology List (ACSTL) and the Transport Canada (TC) Air Cargo Security Program (ACS).

DETECTION OF EXPLOSIVES AND NARCOTICS ALERT

Target™ and NARCSan™ are designed to assist operators in the detection of a range of explosives and narcotics respectively in real time during the scanning process by marking a potential threat on the X-ray image. Rapiscan detection algorithms are based on regulatory material analysis techniques.

EASE OF USE PROVIDING HIGHEST THROUGHPUT

With over 13 image processing tools and detection alert algorithms the feature rich software allows the operator to more easily and accurately search for contraband.

DUAL VIEW ADVANCED TECHNOLOGY

As mandated by US and EU regulators, the 627DV utilizes a Dual View technology which produces two simultaneous images (vertical and horizontal views) of the scanned object. It provides a more complete image, thereby reducing the need for repositioning and rescanning and enabling rapid, accurate and comprehensive threat detection.





627DV RAPISCAN

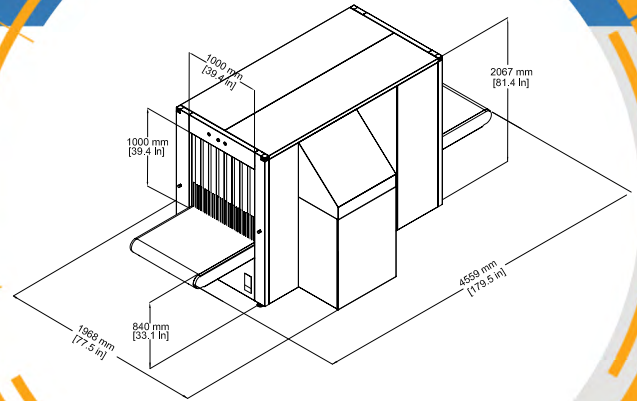

PHYSICAL SPECIFICATIONS

Dimensions:	Length: 4,559 mm (179.5 in.) Width: 1,968 mm (77.5 in.) Height: 2,067 mm (81.4 in.)
Tunnel size:	1,000 mm (W) x 1,000 mm (H) (39.4 x 39.4 in.)
Conveyor speed:	0.20 m/sec (39.4 ft./min)
Conveyor load (Max):	200 Kg (440 lbs)
Conveyor height (Approx.):	840 mm (33.1 in.)
Weight (Approx.):	Net: 1,653 Kg (3,644 lbs)
System power:	115/230 VAC +10% / 60/50Hz

X-RAY GENERATOR AND IMAGE PERFORMANCE¹

Steel penetration:	40 mm typical; 35 mm standard
Resolution:	40 AWG typical; 38 AWG standard
Cooling:	Sealed oil bath with forced air
Anode voltage:	Operating at 160kV
Tube current:	1 mA
Orientation:	Vertically upward

OPERATING ENVIRONMENT

Storage temperature:	-20°C to 50°C
Operating temperature:	0°C to 40°C
Relative humidity:	5 to 95% non-condensing

PROTECTION CLASS

System:	IP20
Operator Control Panel:	IP43 ²

GOVERNMENT REGULATORY

TSA Air Cargo Screening Technology List (ACSTL) Qualified
 Transport Canada (TC) Air Cargo Qualified
 Regulation (EC) No. 300/2008 Compliant
 Regulation (EU) No. 2015/1998 Compliant
 EU Commissions Decision (EU) C(2015) 8005 Compliant
 French Civil Aviation Authority (STAC) Certified

HEALTH & SAFETY

Rapiscan Systems' cabinet X-ray products comply with all applicable U.S. FDA and equivalent international regulatory agency requirements, contained in the cabinet X-ray radiation safety performance standard [21 CFR 1020.40] and the general performance standard [21 CFR Part 1010] as well as IEC standard 61010-2-091. Rapiscan baggage and parcel inspection systems radiation emission leakages are well below the required regulatory limits with less than 1 µSv/hr at 10 cm from all surfaces of cabinet X-ray.

OPTIONS AND ACCESSORIES

- Explosives detection alert (Target™)
- Narcotics detection alert (NARCScan™)
- Density threshold alert (DTA)
- Threat image projection (TIP)
- Threat image projection network (TIPNet)
- Remote image archive review (NETView™)
- Network X-ray management automation and link system (NEXLink™)
- Multi-System network display station (NDS)
- Automatic image archiving
- Enhanced image archiving
- Operator training program (OTP)
- Manual scan
- Operator pedestal
- Foot mat
- Optical operator presence sensor
- Smartcard login
- Power conditioner
- Conveyor accessories
- Remote workstation
- Universal printer support

(1) Stated performance as measured by Rapiscan Imaging Validation Test Kit.
 (2) With optional replaceable cover.

With continual development of our products Rapiscan Systems reserves the right to amend specifications without notice. Product pictures are for general reference. Please note that due to US laws and regulations, not all Rapiscan products are available for sale in all countries without restriction. Please contact your Rapiscan Systems sales representative for more information.

HTDS

Parc d'Activités du Moulin de Massy - 3 rue du Saule Trapu
 BP246 - 91882 Massy Cedex France
 Tel : +33 (0) 1 64 86 28 28 - Fax : +33 (0) 1 69 07 69 54 - info@htds.fr - www.htds.fr

HTDS Algeria: +213 232 384 01/02 HTDS Morocco: +212 222 749 59
 HTDS Egypt: +202 229 053 06 HTDS Lybia: +218 91 69 50 70 8
 HTDS Madagascar: +261 34 40 664 72 HTDS Tunisia: +216 70 836 961