



## 628DV RAPISCAN

DUAL VIEW TECHNOLOGY, EASY LOADING CONVEYOR AND LARGE TUNNEL FOR X-RAY SCREENING OF LARGE BAGGAGE AND SMALL CARGO

- ▶ LARGE PARCEL AND SMALL CARGO SCREENING
- ▶ HIGH IMAGE QUALITY FOR COMPLEX PARCELS
- ▶ EASY LOADING CONVEYOR
- ▶ DUAL VIEW TECHNOLOGY

### STANDARD FEATURES

- Multi energy imaging (4 Color)
- View previous/next bag
- Image archive
- Configurable image processing keys
- Baggage counter
- Date / time display
- Search indicator
- UPS (Uninterrupted Power Supply)
- Multi language support
- Flat panel monitor

### STANDARD IMAGE PROCESSING FUNCTIONS

- Crystal clear™
- Black and white
- Organic / inorganic stripping
- Inverse video
- High penetration
- Pseudo color
- Low penetration
- Variable edge enhancement
- Variable color stripping
- Variable gamma
- Variable density
- Dynamic continuous zoom & panning
- Fixed zoom (64x)



TUNEL OPENING (WXH) :  
1,000 x 1,000 mm (39.4 x 39.4 in)

WITH A LARGE TUNNEL OPENING OF AND A LOW CONVEYOR, **THE RAPISCAN 628DV** IS DESIGNED FOR SCREENING SMALL CARGO AS WELL AS BAGGAGE AND LARGE PARCELS FOR AIR CARGO, CUSTOMS, CRITICAL INFRASTRUCTURE PROTECTION AS WELL AS AVIATION CHECK-IN SCREENING APPLICATIONS.

### DETECTION OF EXPLOSIVES AND NARCOTICS ALERT

Target™ and NARCScan™ are designed to assist operators in the detection of a range of explosives and narcotics respectively in real time during the scanning process by marking a potential threat on the X-ray image. Rapiscan detection algorithms are based on regulatory material analysis techniques.

### EASE OF USE PROVIDING HIGHEST THROUGHPUT

With over 13 image processing tools and detection alert algorithms the feature rich software allows the operator to more easily and accurately search for contraband.

### DUAL VIEW ADVANCED TECHNOLOGY

As mandated by US and EU regulators, the 628DV utilizes a dual-view technology which produces two simultaneous images (vertical and horizontal views) of the scanned object. It provides a more complete image, thereby reducing the need for repositioning and rescanning and enabling rapid, accurate and comprehensive threat detection.





## 628DV RAPISCAN

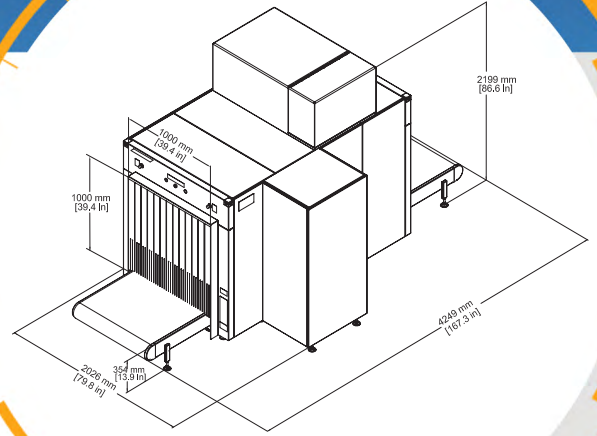

### PHYSICAL SPECIFICATIONS

Dimensions:	Length: 4,249 mm (167.3 in.) Width: 2,026 mm (79.8 in.) Height: 2,199 mm (86.6 in.)
Tunnel size:	1,000 mm (W) x 1,000 mm (H) (39.4 x 39.4 in.)
Conveyor speed:	0.20 m/sec (39.4 ft./min)
Conveyor load (Max):	165 Kg (364 lbs) evenly distributed
Conveyor height (Approx.):	354 mm (13.9 in.)
Weight (Approx.):	Net: 1,772 Kg (3,907 lbs)
System power:	115/230 VAC 310%, 60/50Hz

### X-RAY GENERATOR AND IMAGE PERFORMANCE<sup>(1)</sup>

Steel penetration:	30 mm typical; 28 mm standard
Resolution:	40 AWG typical; 38 AWG standard
Cooling:	Sealed oil bath with forced air
Anode voltage:	Operating at 160kV
Tube current:	1.0 mA
Orientation:	Vertically downward

### OPERATING ENVIRONMENT

Storage temperature:	-20°C to 50°C
Operating temperature:	0°C to 40°C
Relative humidity:	5 to 95% non-condensing

### PROTECTION CLASS

System:	IP20
Operator control panel:	IP43 <sup>2</sup>

### GOVERNMENT REGULATORY

TSA Air Cargo Screening Technology List (ACSTL) Qualified  
 Transport Canada (TC) Air Cargo Qualified  
 Regulation (EC) No. 300/2008 Compliant  
 Regulation (EU) No. 2015/1998 Compliant  
 EU Commissions Decision (EU) C(2015) 8005 Compliant  
 French Civil Aviation Authority (STAC) Certified

### HEALTH & SAFETY

Rapiscan Systems' cabinet X-ray products comply with all applicable U.S. FDA and equivalent international regulatory agency requirements, contained in the cabinet X-ray radiation safety performance standard [21 CFR 1020.40] and the general performance standard [21 CFR Part 1010] as well as IEC standard 61010-2-091. Rapiscan baggage and parcel inspection systems radiation emission leakages are well below the required regulatory limits with less than 1 µSv/hr at 10 cm from all surfaces of cabinet X-ray

### OPTIONS AND ACCESSORIES

- Explosives detection alert (Target™)
- Narcotics detection alert (NARCSan™)
- Density threshold alert (DTA)
- Threat image projection (TIP)
- Threat image projection network (TIPNet)
- Remote image archive review (NETView™)
- Network X-ray management automation and link system (NEXLink™)
- Multi-system network display station (NDS)
- Automatic image archiving
- Enhanced image archiving
- Operator training program (OTP)
- Manual scan
- Operator pedestal
- Foot mat
- Optical operator presence sensor
- Smartcard login
- Power conditioner
- Conveyor accessories
- Remote workstation
- Universal printer support

(1) Stated performance as measured by Rapiscan Imaging Validation Test Kit.  
 (2) With optional replaceable cover.

With continual development of our products Rapiscan Systems reserves the right to amend specifications without notice. Product pictures are for general reference. Please note that due to US laws and regulations, not all Rapiscan products are available for sale in all countries without restriction. Please contact your Rapiscan Systems sales representative for more information.

### HTDS

Parc d'Activités du Moulin de Massy – 3 rue du Saule Trapu  
 BP246 - 91882 Massy Cedex France  
 Tel : +33 (0) 1 64 86 28 28 – Fax : +33 (0) 1 69 07 69 54 – info@htds.fr – www.htds.fr

HTDS Algeria: +213 232 384 01/02      HTDS Morocco: +212 222 749 59  
 HTDS Egypt: +202 229 053 06      HTDS Lybia: +218 91 69 50 70 8  
 HTDS Madagascar: +261 34 40 664 72      HTDS Tunisia: +216 70 836 961