

YAG series – YAG-100AH, YAG-200H and YAG-444AH

Long Wavelength Enhanced Silicon PIN Photodiodes



The YAG series high-performance Si PIN photodiodes are well-suited for applications using 1064 nm (YAG) lasers.

Key Features and Benefits

- Planar Diffused
- Large Area
- Wide Dynamic Range
- >50% DC Quantum Efficiency at 1064 nm
- >38% Pulsed Quantum Efficiency at 1064 nm with 20 ns Pulse Width
- Wide Spectral Range
- >90% DC Quantum Efficiency at 900 nm
- Peak Responsivity: 0.7 A/W at 1000 nm

Applications

- Instrumentation
- Laser range finding
- Laser warning receivers
- Missile guidance systems

The YAG series are high-performance P-type Si PIN photodiodes in hermetically sealed TO packages. These photodiodes perform well over the 400 nm to 1100 nm wavelength range and use a thicker Si material for enhanced IR responsivity, making them ideal for 1064 nm detection applications, while maintaining fast response time.

A guard ring has been implemented to collect the higher surface leakage current of a P-type detector. This also serves to collect current generated outside the active area, ensuring the current will not contribute to noise. This is advantageous for applications when the entire chip is illuminated or when nuclear particles outside the active area could create noise.

Recognizing that different applications have different performance requirements, Excelitas offers a wide range of customization of these photodiodes to meet your design challenges. Responsivity and noise screening, N-type variants, YAG-optimized anti-reflection coatings (ARC) on the window, varying pin length and custom device testing and packaging are among many of the application specific solutions available.

YAG series – YAG-100AH, YAG-200H and YAG-444AH

Long Wavelength Enhanced Silicon PIN Photodiodes

Table 1 - Mechanical and Optical Characteristics

Parameter	YAG-100AH	YAG-200H	YAG-444AH	Unit
Shape	Circular, single element	Circular, single element	Circular, single element	
Photosensitive Surface:				
Useful area	4.9	20	100	mm ²
Useful diameter	2.5	5.1	11.3	mm
Package	TO-5	TO-8	TO-36	
Window Type	Glass	Glass	Glass	

Table 2 – Electro-Optical Characteristics

Operating data and specifications at 23°C – typical performance at 180V voltage bias

Parameter	Symbol	YAG-100AH			YAG-200H			YAG-444AH			Units
		Min	Typical	Max	Min	Typical	Max	Min	Typical	Max	
Active area	A		5.1			20			100		mm ²
Spectral range		400		1150	400		1150	400		1150	nm
Responsivity at 1000 nm at 1064 nm at 1064 nm (window ARC)	R		0.70 0.44 0.47			0.70 0.44 0.47			0.70 0.44 0.47		A/W
Bandwidth (1060nm, 50Ω load)			30			30			30		MHz
Rise time, R _L = 50Ω	t _r		12			12			12		ns
Operating voltage	V _{op}	0		180	0		180	0		180	V
Breakdown voltage ¹	V _{br}	200			200			200			V
Capacitance	C _d		2.5			6.0			35		pF
Dark current	i _d		11	20		25	100		80	200	nA
Channel resistance			>1.0			>1.0			>1		MΩ
Series resistance	R _s		100			100			100		Ω
Noise current	i _n		0.06			0.09			0.16		pA/√Hz
Noise equivalent power (1000 nm, 1 MHz)	NEP		0.08			0.13			0.23		pW/√Hz
Response linearity			<1%			<1%			<1%		Over 7 decades
Operating Temperature	T _o	-55		125	-55		125	-55		125	°C
Field of View: (See Figure 6) Nominal field of view α Nominal field of view α'	FoV		1 95			135 155			105 160		Degrees

¹ Breakdown voltage (Vbr) measurement at 100 μA dark current (Id)

Long Wavelength Enhanced Silicon PIN Photodiodes

Figure 1 – Typical Spectral Response

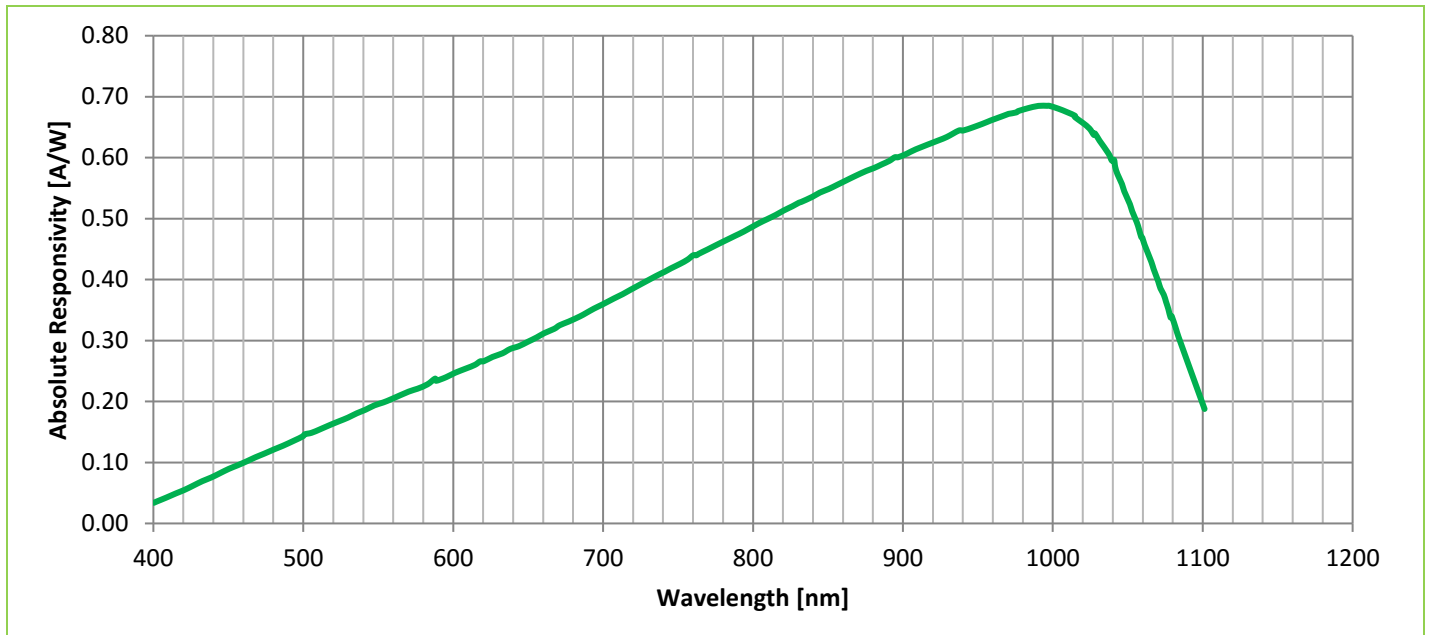
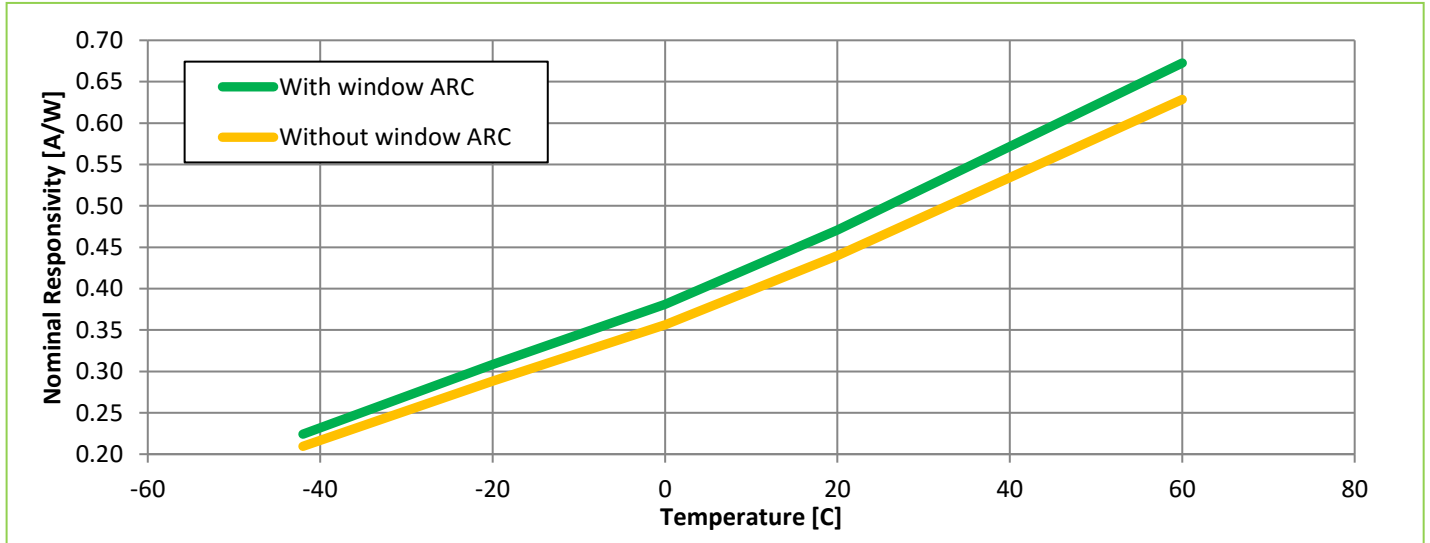

Figure 2 – Typical increase in responsivity as a function of photodiode temperature



Long Wavelength Enhanced Silicon PIN Photodiodes

Figure 3 – YAG-100AH Package Dimensions (reference only and subject to change without notice)

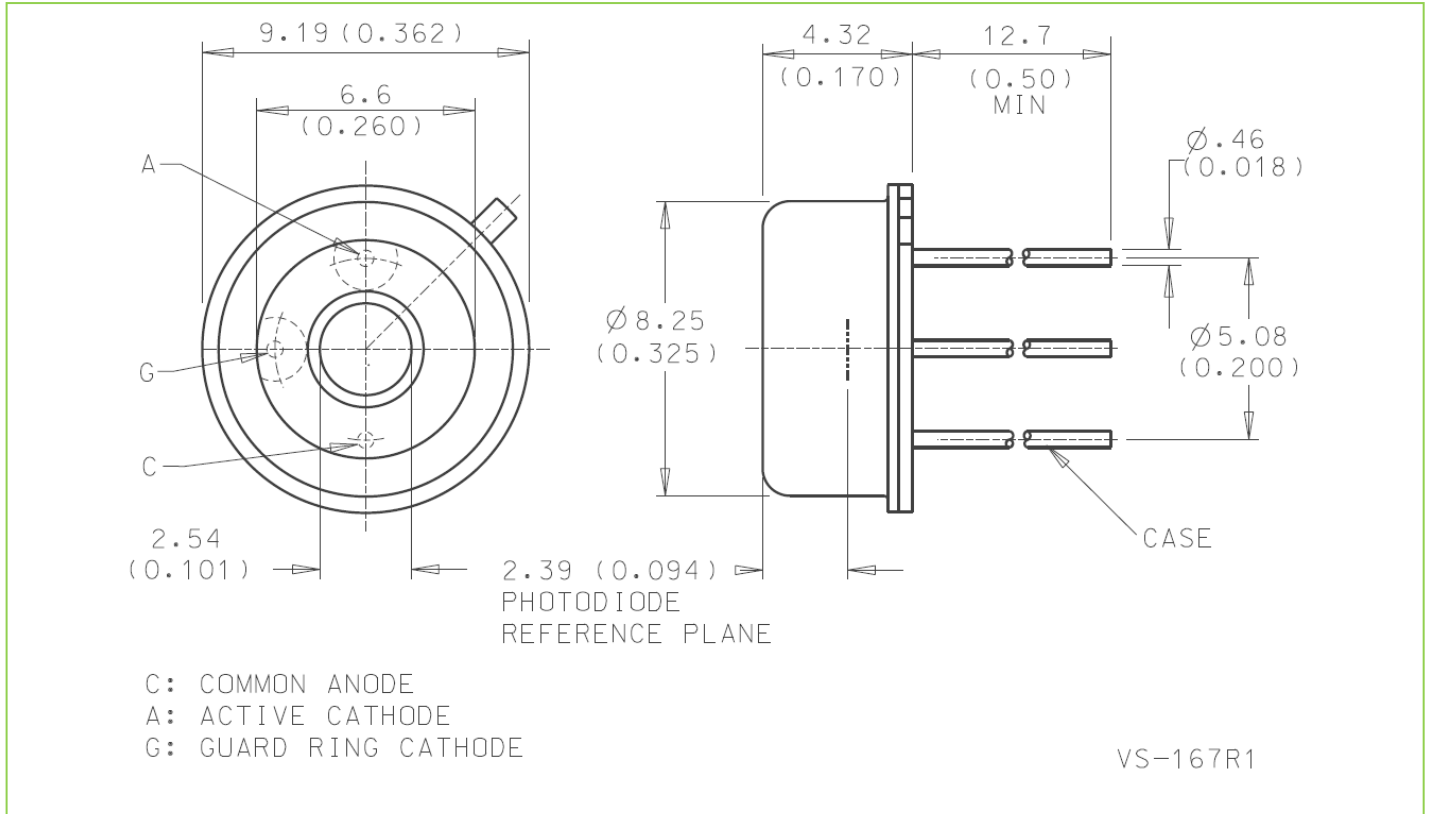
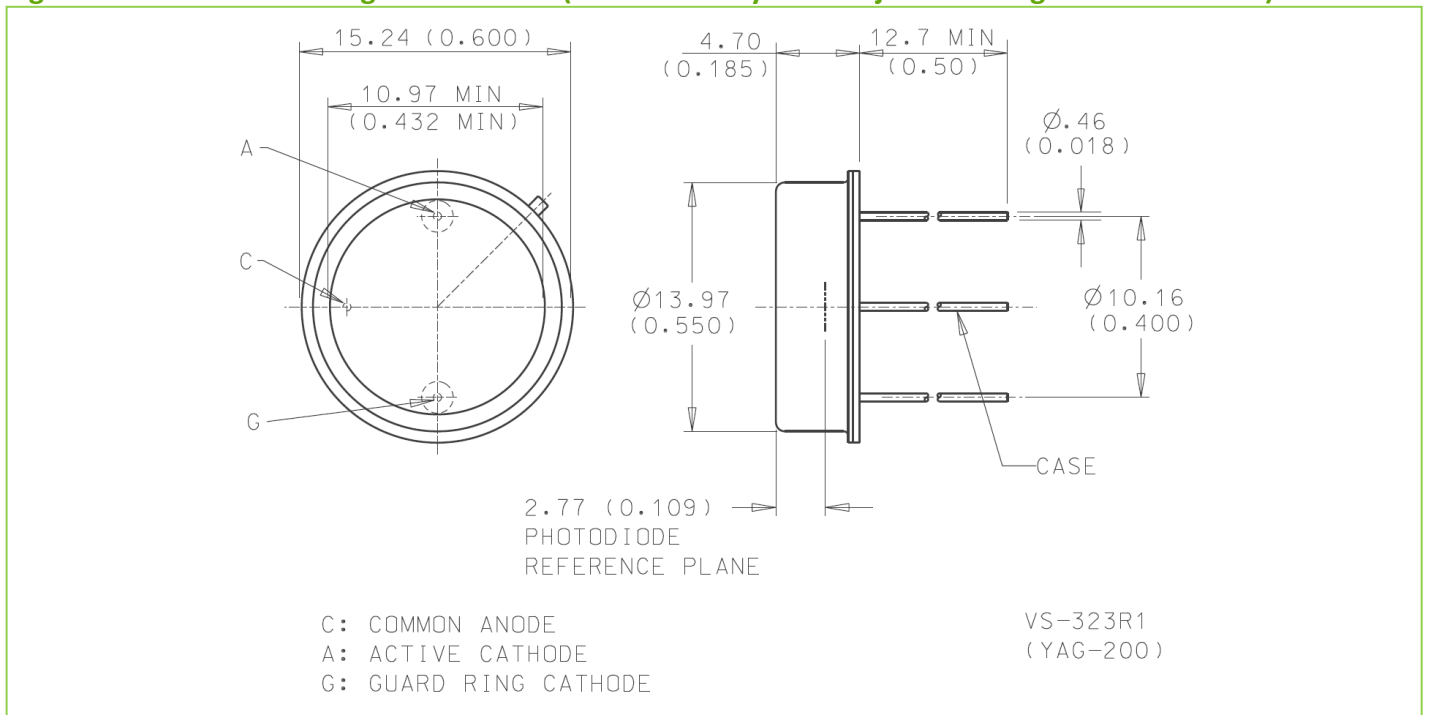

Figure 4 – YAG-200H Package Dimensions (reference only and subject to change without notice)



Long Wavelength Enhanced Silicon PIN Photodiodes

Figure 5 – YAG-444AH Package Dimensions (reference only and subject to change without notice)

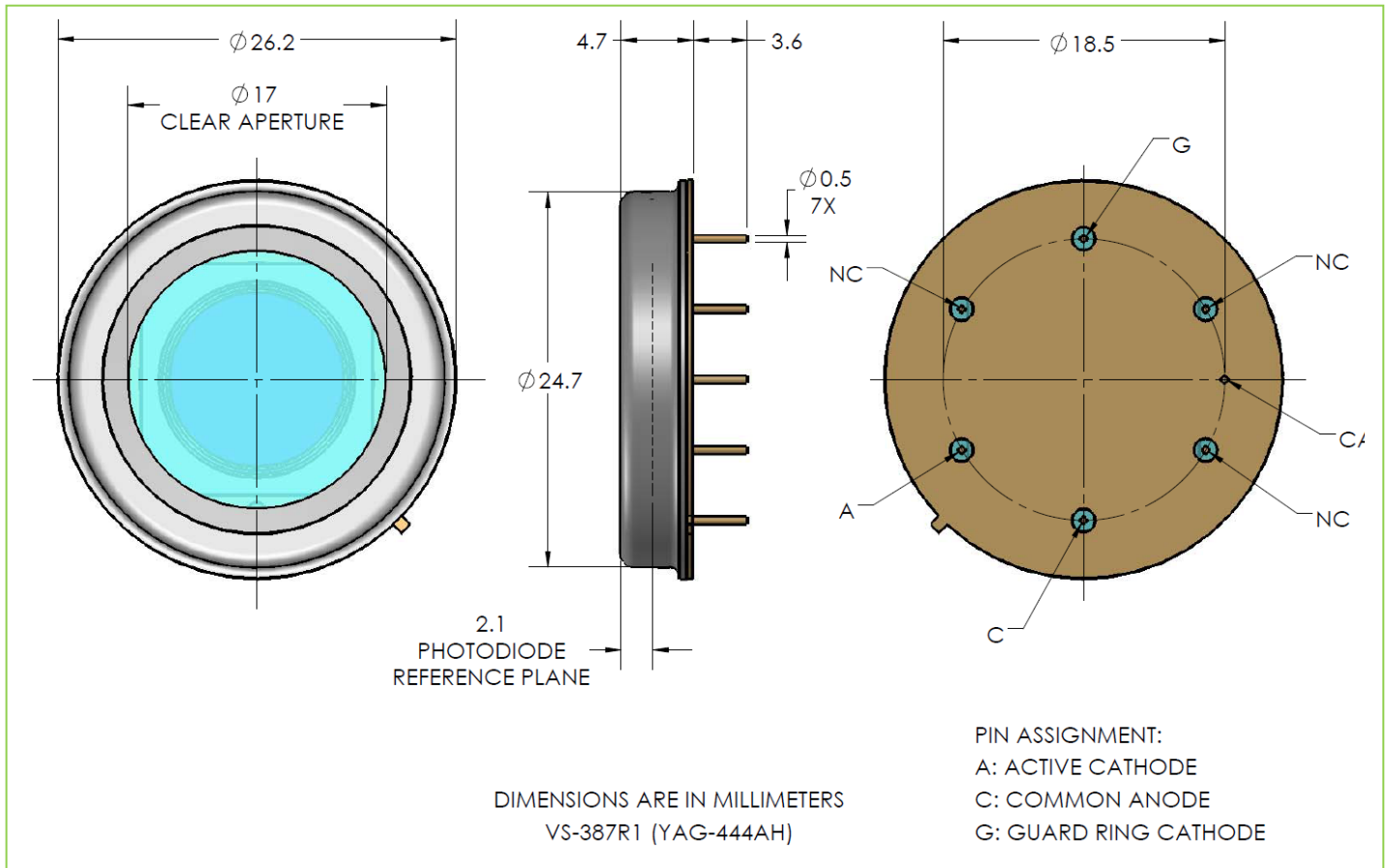
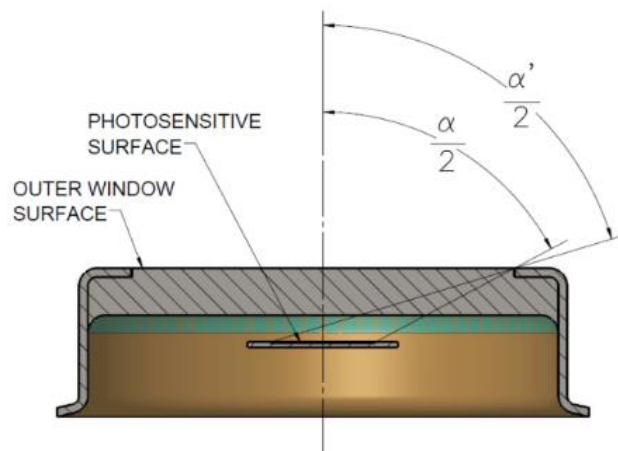

Figure 6 – Approximate field of view

For incident radiation at angles $\leq \alpha/2$, the photosensitive surface is totally illuminated.
For incident radiation at angles $> \alpha/2$, but $\leq \alpha'/2$, the photosensitive surface is partially illuminated.



VS-383

YAG series – YAG-100AH, YAG-200H and YAG-444AH

Long Wavelength Enhanced Silicon PIN Photodiodes

Export controls

Due to specific parameters, some of these photodiodes fall under the Canada's Export Controls List (ECL) and require an End User Statement from all purchasing parties as an export permit may be required for some destinations.

RoHS Compliance

The YAG-100AH and YAG-444AH is designed and built to be fully compliant with the European Union Directive 2011/65/EU – Restriction of the use of certain Hazardous Substances (RoHS) in Electrical and Electronic equipment.



Warranty

A standard 12-month warranty following shipment applies. Any warranty is null and void if the photodiode window has been opened.

About Excelitas Technologies

Excelitas Technologies is a global technology leader focused on delivering innovative, customized solutions to meet the lighting, detection and other high-performance technology needs of OEM customers.

Excelitas has a long and rich history of serving our OEM customer base with optoelectronic sensors and modules for more than 45 years beginning with PerkinElmer, EG&G, and RCA. The constant throughout has been our innovation and commitment to delivering the highest quality solutions to our customers worldwide.

From analytical instrumentation to clinical diagnostics, medical, industrial, safety and security, and aerospace and defense applications, Excelitas Technologies is committed to enabling our customers' success in their specialty end-markets. Excelitas Technologies has approximately 3,000 employees in North America, Europe and Asia, serving customers across the world.

Excelitas Technologies
22001 Dumberry Road
Vaudreuil-Dorion, Quebec
Canada J7V 8P7
Tel.: (+1) 450.424.3300
Toll-free: (+1) 800.775.6786
Fax: (+1) 450.424.3345
detection.na@excelitas.com

Excelitas Technologies
GmbH & Co. KG
Wenzel-Jaksch-Str. 31
D-65199 Wiesbaden
Germany
Telephone: (+49) 611 492 430
Fax: (+49) 611 492 165
detection.europe@excelitas.com

Excelitas Technologies
Singapore, Pte. Ltd.
8 Tractor Road
Singapore 627969
Telephone: (+65) 6775 2022
Telephone: (+65) 6770 4366
(Customer Service)
Fax: (+65) 6778-1752
detection.asia@excelitas.com

Excelitas Technologies
International Sales Office
Bat HTDS BP 246, 91882
Massy Cedex
France
Telephone: +33 1 6486 2824
europedefense@excelitas.com



For a complete listing of our global offices, visit www.excelitas.com/locations

© 2012 Excelitas Technologies Corp. All rights reserved. The Excelitas logo and design are registered trademarks of Excelitas Technologies Corp. All other trademarks not owned by Excelitas Technologies or its subsidiaries that are depicted herein are the property of their respective owners. Excelitas reserves the right to change this document at any time without notice and disclaims liability for editorial, pictorial or typographical errors.