

Features

- Gallium nitride based material
- Broad band UVA+UVB+UVC photodiode
- Photovoltaic mode operation
- TO 39 package
- Good visible blindness
- High responsivity and low dark current



Applications

- UV index monitoring
- UV radiation dose measurement
- Flame detection

Specifications

Parameter	Symbol	Value	Unit
Spectral characteristics (25 °C)			
Wavelength of peak responsivity	λ_{max}	355	nm
Peak responsivity (at 355 nm)	R_{max}	0.18	A/W
Spectral response range	-	180~370	nm
UV/visible rejection ratio ($R_{max}/R_{400\text{ nm}}$)	VB	$>10^4$	-
General characteristics (25 °C)			
Chip size	A	4	mm ²
Dark current (1 V reverse bias)	I_d	<1	nA
Capacitance (at 0 V and 1 MHz)	C	72	pF
Temperature coefficient	T_c	-0.1	%/°C
Maximum ratings			
Operation temperature range	T_{opt}	-28~85	°C
Storage temperature range	T_{stor}	-40~85	°C
Soldering temperature (3 s)	T_{sold}	260	°C
Reverse voltage	V_{Rmax}	10	V

Spectral response

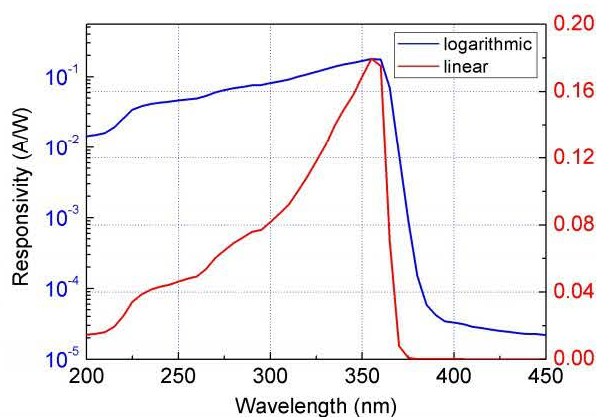

Package dimensions

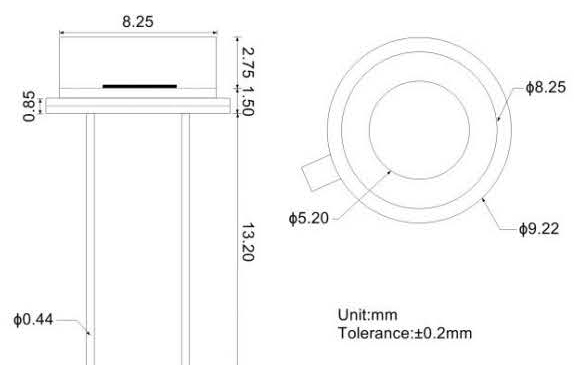

***Caution:** ESD can damage the device hence please avoid ESD.